

Uninformed Search

- Problem-solving agents
 - Single-State Problems
- Tree search algorithms
 - Breadth-First Search
 - Depth-First Search
 - Limited-Depth Search
 - Iterative Deepening
- Search with Partial Information

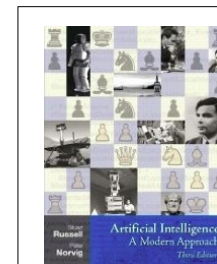

Many slides based on
Russell & Norvig's slides
**Artificial Intelligence:
A Modern Approach**

Problem-Solving Agents

- Simple reflex agents
 - have a direct mapping from states to actions
 - typically too large to store
 - would take too long to learn
- Goal-Based agents
 - can consider future actions and the desirability of their outcomes (→ Planning)
- Problem-Solving Agents
 - special case of Goal-Based Agents
 - find sequences of actions that lead to desirable states
- Uninformed Problem-Solving Agents
 - do not have any information except the **problem definition**
- Informed Problem-Solving Agents
 - have **knowledge where to look** for solutions

Goal-Based Agent

- the agent knows what states are desirable
 - it will try to choose an action that leads to a desirable state

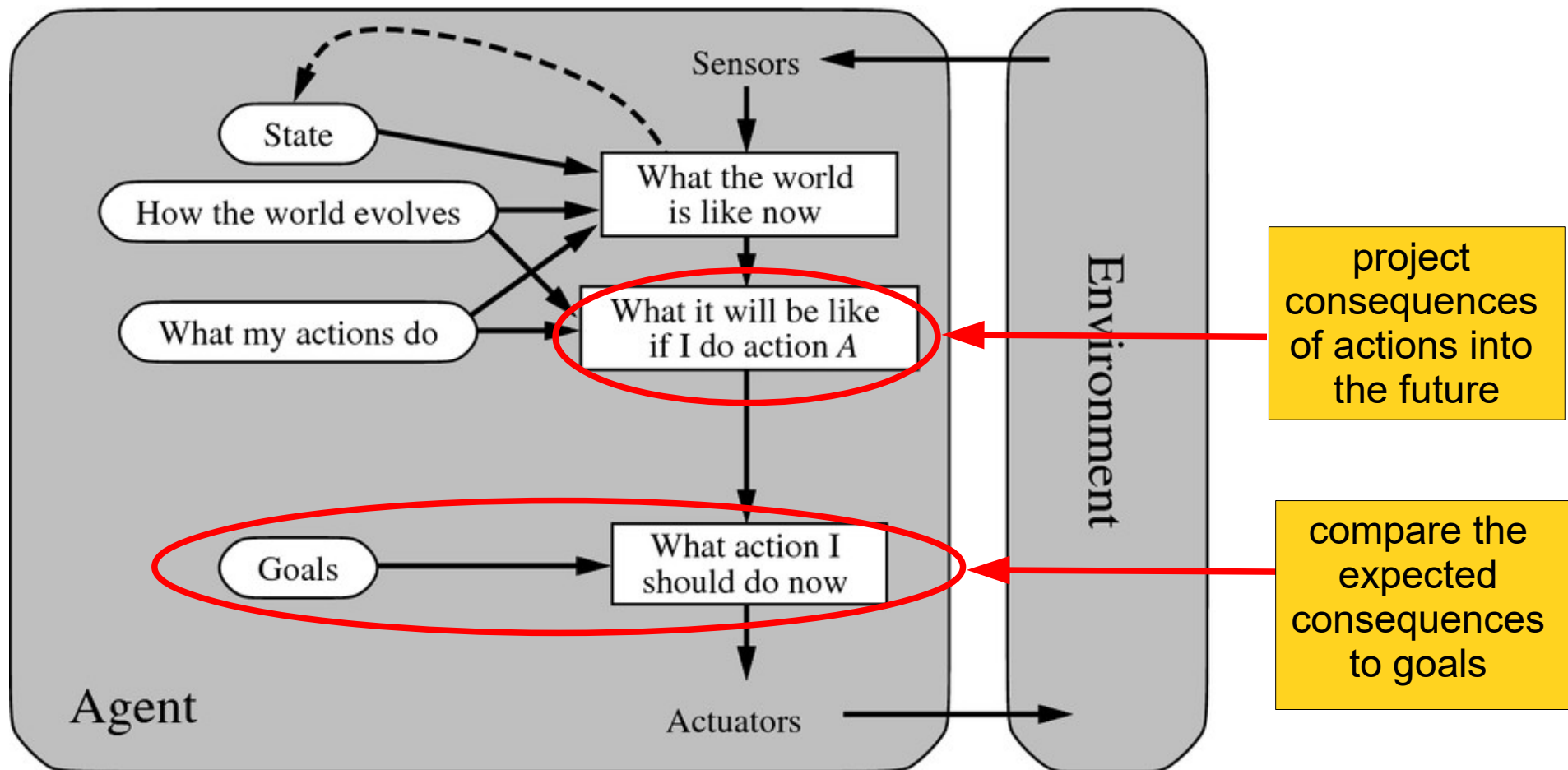

Formulate-Search-Execute Design

- **Formulate:**
 - **Goal formulation:**
 - A *goal* is a set of world states that the agents wants to be in (where the goal is achieved)
 - Goals help to organize behavior by limiting the objectives that the agent is trying to achieve
 - **Problem formulation:**
 - Process of which actions and states to consider, given a goal
- **Search:**
 - the process of finding the solution for a problem in the form of an action sequence

*an agent with several immediate options of unknown value can decide what to do by **examining different possible sequences of actions that lead to states of known value, and then choosing the best***
- **Execute:**
 - perform the first action of the solution sequence

Simple Problem-Solving Agent

```
function SIMPLE-PROBLEM-SOLVING-AGENT(percept) returns an action
  static: seq, an action sequence, initially empty
           state, some description of the current world state
           goal, a goal, initially null
           problem, a problem formulation

  state ← UPDATE-STATE(state, percept)
  if seq is empty then
    goal ← FORMULATE-GOAL(state)
    problem ← FORMULATE-PROBLEM(state, goal)
    seq ← SEARCH(problem)
  action ← RECOMMENDATION(seq, state)
  seq ← REMAINDER(seq, state)
  return action
```

Example: Navigate in Romania

- On holiday in Romania; currently in Arad.
- Flight leaves tomorrow from Bucharest
- **Formulate goal:**
 - be in Bucharest
- **Formulate problem:**
 - **states:** various cities
 - **actions:** drive between cities
- **Find solution:**
 - sequence of cities, e.g., Arad, Sibiu, Rimnicu Vilcea, Pitesti
- **Assumption:**
 - agent has a map of Romania, i.e., it can use this information to find out which of the three ways out of Arad is more likely to go to Bucharest

Example: Romania

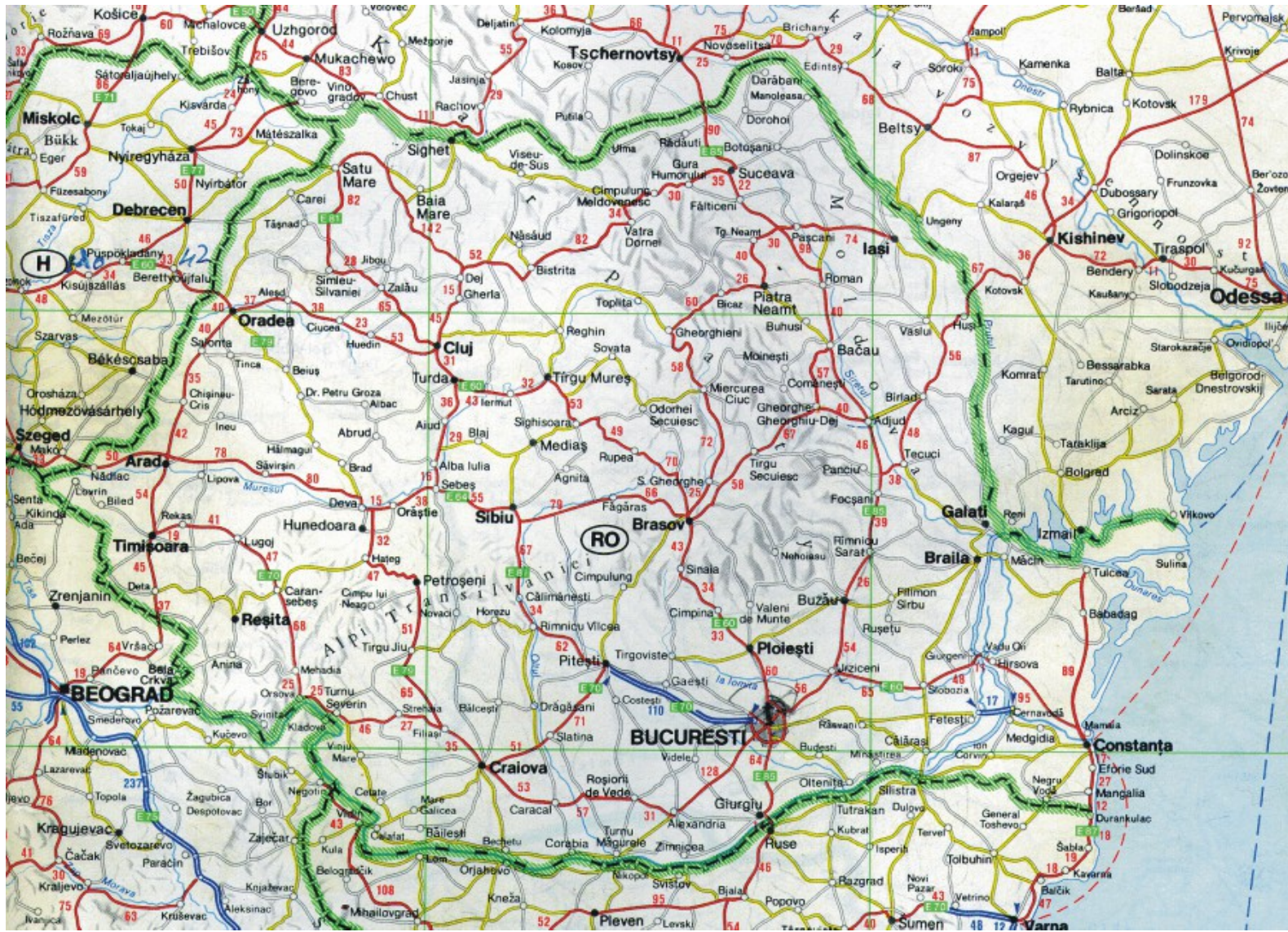

Single-state Problem Formulation

A **problem** is defined by four items:

- **initial state**
 - e.g., "at Arad"
- description of actions and their effects
 - typically as a **successor function** that maps a state s to a set $S(s)$ of action-state pairs
 - e.g., $S(„at Arad“) = \{ \langle „goto Zerind“, „at Zerind“ \rangle, \dots \}$
- **goal test**, can be
 - explicit, e.g., $s = \text{"at Bucharest"}$
 - implicit, e.g., $\text{Checkmate}(s)$, $\text{NoDirt}(s)$
- **path cost** (additive)
 - e.g., sum of distances, number of actions executed, etc.
 - $c(s_1, a, s_2)$ are the costs for one step (one action),
 - assumed to be ≥ 0

Single-State Problems

Yes

- 8-queens puzzle
- 8-puzzle
- Towers of Hanoi
- Cross-Word puzzles
- Sudoku
- Chess, Bridge, Scrabble puzzles
- Rubik's cube
- Sobokan
- Traveling Salesman Problem

No

- Tetris
 - dynamic not static
- Solitaire
 - only partially observable

State Space of a Problem

State Space

- the set of all states reachable from the initial state
- implicitly defined by the initial state and the successor function

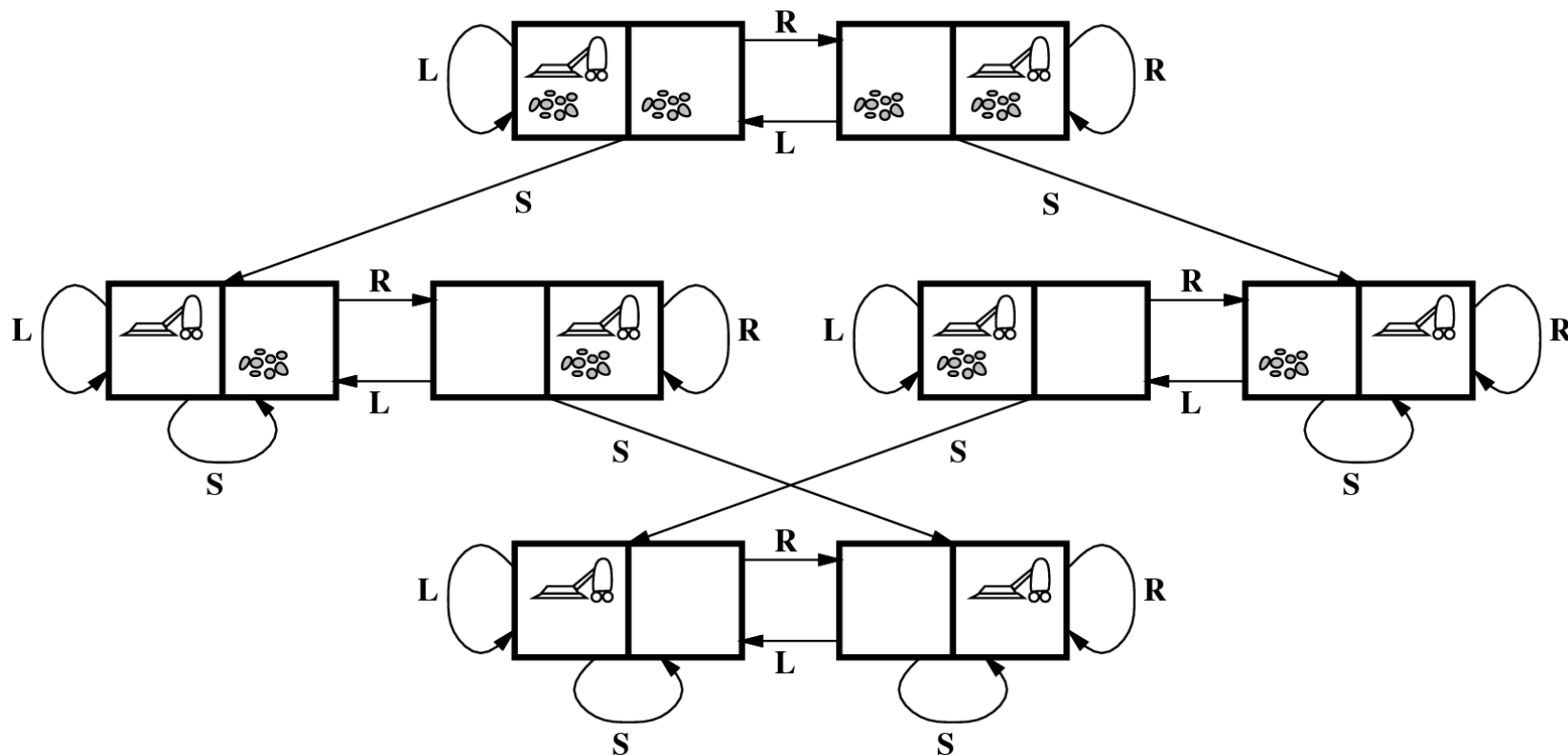

State Space of a Problem

- **State Space**
 - the set of all states reachable from the initial state
 - implicitly defined by the initial state and the successor function
- **Path**
 - a sequence of states connected by a sequence of actions
- **Solution**
 - a path that leads from the initial state to a goal state
- **Optimal Solution**
 - solution with the minimum path cost

Example: Romania

[Saved Locations](#) | [Sign in](#) | [Help](#)



[Web](#) [Images](#) [Video](#) [News](#) [Maps](#) [Desktop](#) [more »](#)

arad, romania

bucharest, romania

Get Directions

[Search the map](#)

[Find businesses](#)

[Get directions](#)

Maps

[Print](#) [Email](#) [Link to this page](#)

Search Results

My Maps [New!](#)

[Get reverse directions](#)

From: Arad
Romania

Drive: 549 km (about 9 hours 20 mins)

1. Head **south** on **79/E671** 0.7 km
2. Turn **left** toward **7/E68** 3.8 km
3. Slight **left** at **7/E68** (signs for **E68/DEVA**) 231 km
4. Turn **right** at **1/7/E68/E81** 0.5 km
5. Slight **left** to stay on **1/7/E68/E81** 32.2 km
6. Turn **right** at **1/7/E68** (signs for **BRAȘOV/RM. VALCEA**) 1.7 km
7. Turn **left** (signs for **BRAȘOV/RM. VALCEA**) 0.7 km
8. Turn **left** toward **7/E81** (signs for **BRAȘOV/RM. VALCEA**) 2.3 km
9. Turn **right** at **7/E81** 72.3 km
Go through 1 roundabout
10. Turn **left** to stay on **7/E81** 6.2 km
11. Turn **left** at **E81** 84.3 km
12. Turn **left** at **65B/E81** 1.9 km
13. Turn **left** at **E70/E81** 104 km

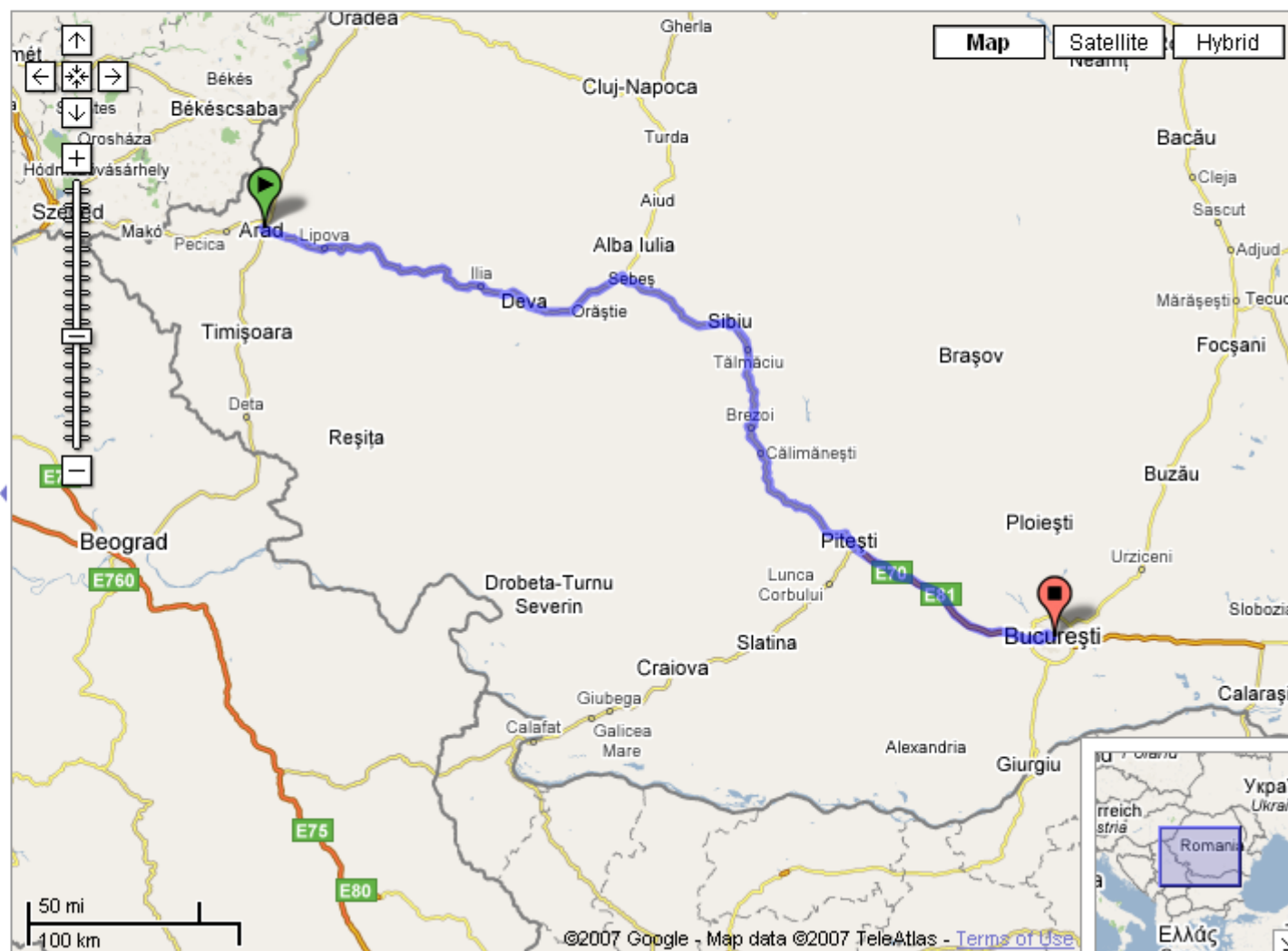

Selecting a State Space

Real world is absurdly complex

→ **state space** must be **abstracted** for problem solving

- (Abstract) state
 - corresponds to a set of real states
- (Abstract) action
 - corresponds to a complex combination of real actions
 - e.g., "go from Arad to Zerind" represents a complex set of possible routes, detours, rest stops, etc.
 - for guaranteed realizability, any real state "in Arad" must get to some real state "in Zerind"
 - each abstract action should be "easier" than the original problem
- (Abstract) solution
 - corresponds to a set of real paths that are solutions in the real world

Example: Romania – State Space

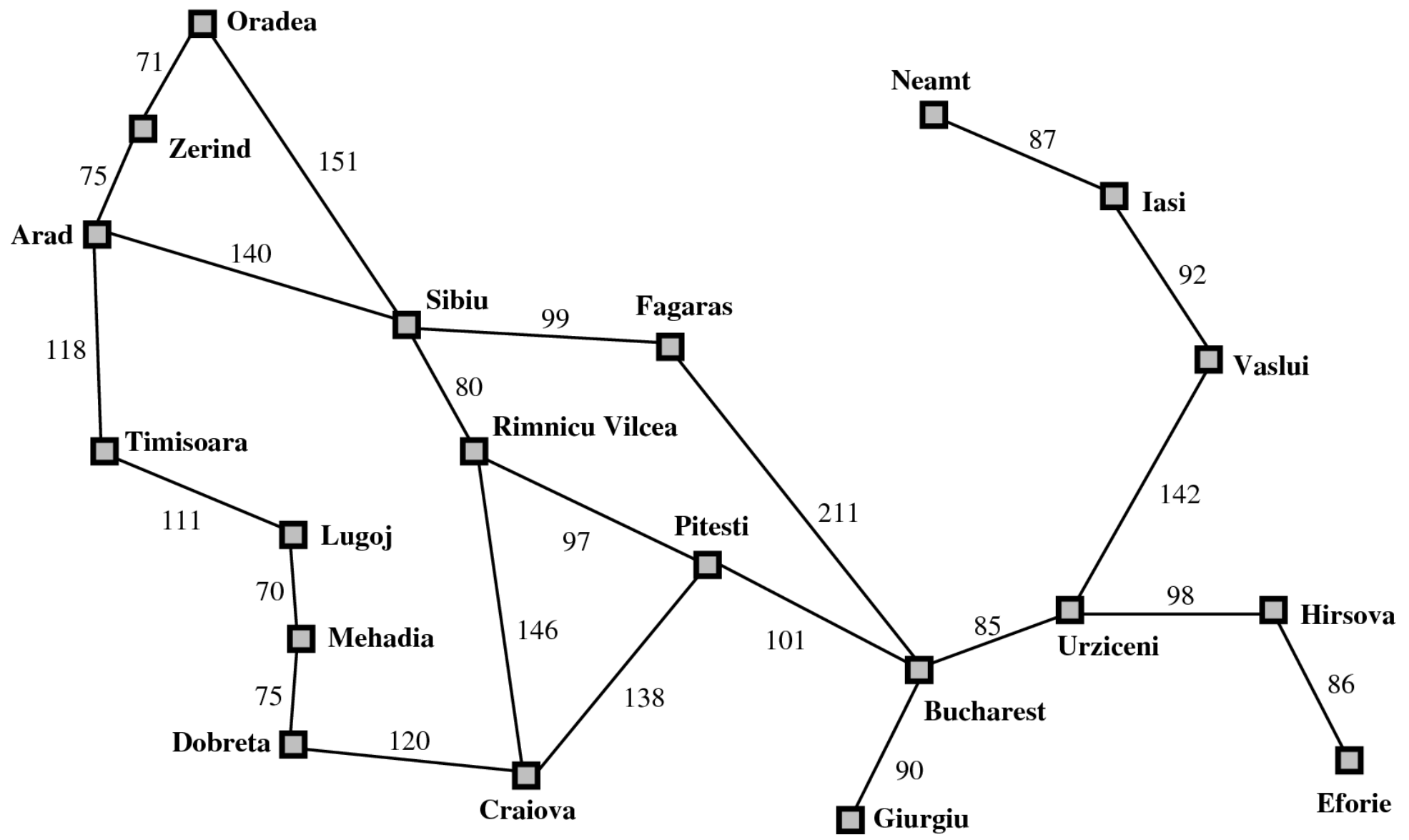

Example: The 8-puzzle

7	2	4
5		6
8	3	1

Start State

	1	2
3	4	5
6	7	8

Goal State

- **states?**
 - location of tiles
 - ignore intermediate positions during sliding
- **goal test?**
 - situation corresponds to goal state
- **path cost?**
 - number of steps in path (each step costs 1)
- **actions?**
 - move blank tile (left, right, up, down)
 - easier than having separate moves for each tile
 - ignore actions like unjamming slides if they get stuck

Example: The 8-Queens Problem

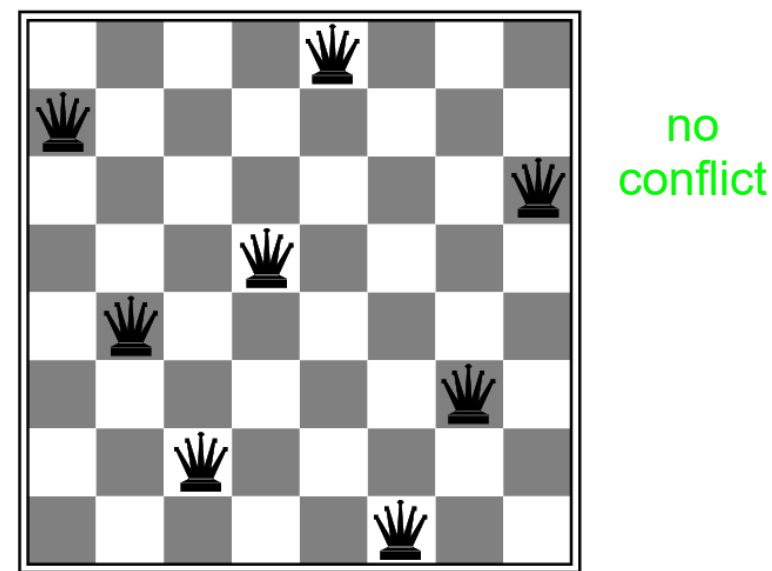
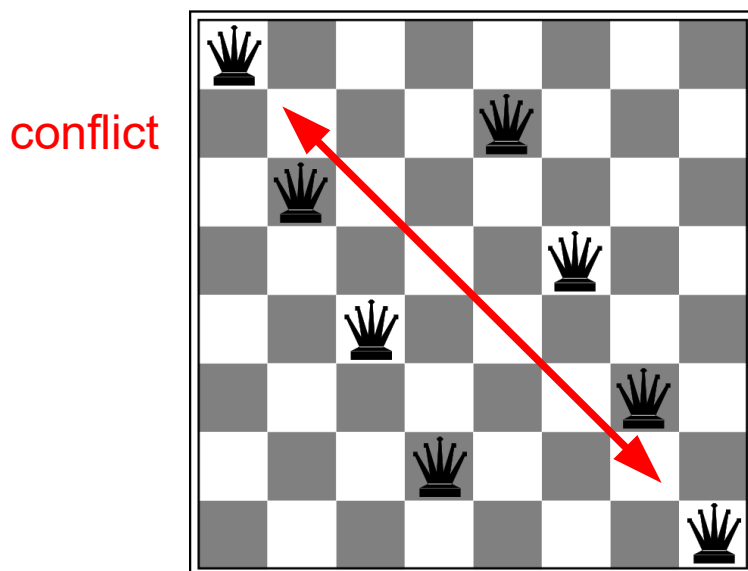

- **states?**
 - any configuration of 8 queens on the board
- **goal test?**
 - no pair of queens can capture each other
- **actions?**
 - move one of the queens to another square
- **path cost?**
 - not of interest here

inefficient complete-state formulation

→ $64 \cdot 63 \cdot \dots \cdot 57 \approx 3 \cdot 10^{14}$ states

Example: The 8-Queens Problem

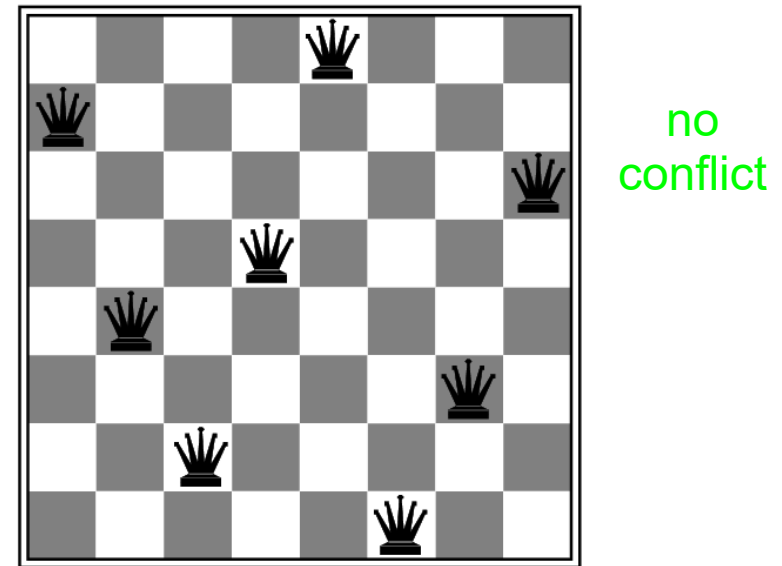
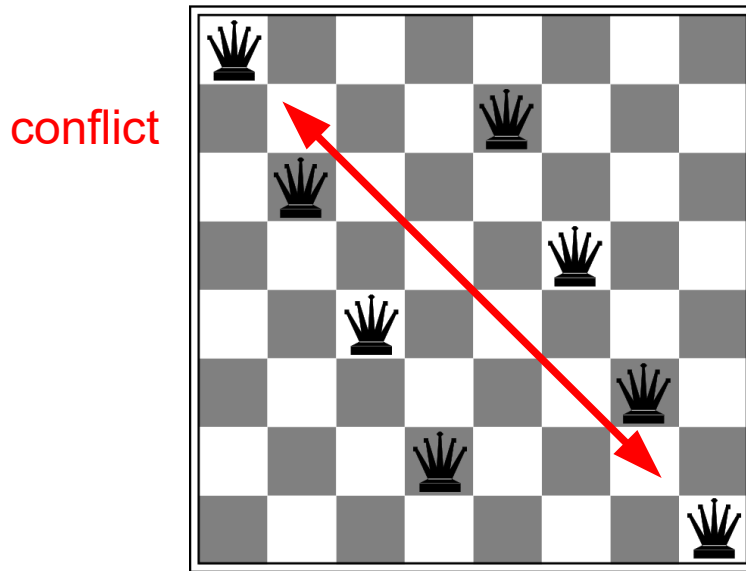

- states?
 - n non-attacking queens in the left n columns
- goal test?
 - no pair of queens can capture each other
- actions?
 - add queen in column $n + 1$
 - without attacking the others
- path cost?
 - not of interest here

more efficient incremental formulation
 → only 2057 states

Tree Search Algorithms

- Treat the state-space graph as a tree
- **Expanding a node**
 - offline, simulated exploration of state space by generating successors of already-explored states (successor function)
- **Search strategy**
 - determines which node is expanded next
- **General algorithm:**

```
function TREE-SEARCH(problem, strategy) returns a solution, or failure
  initialize the search tree using the initial state of problem
  loop do
    if there are no candidates for expansion then return failure
    choose a leaf node for expansion according to strategy
    if the node contains a goal state then return the corresponding solution
    else expand the node and add the resulting nodes to the search tree
  end
```

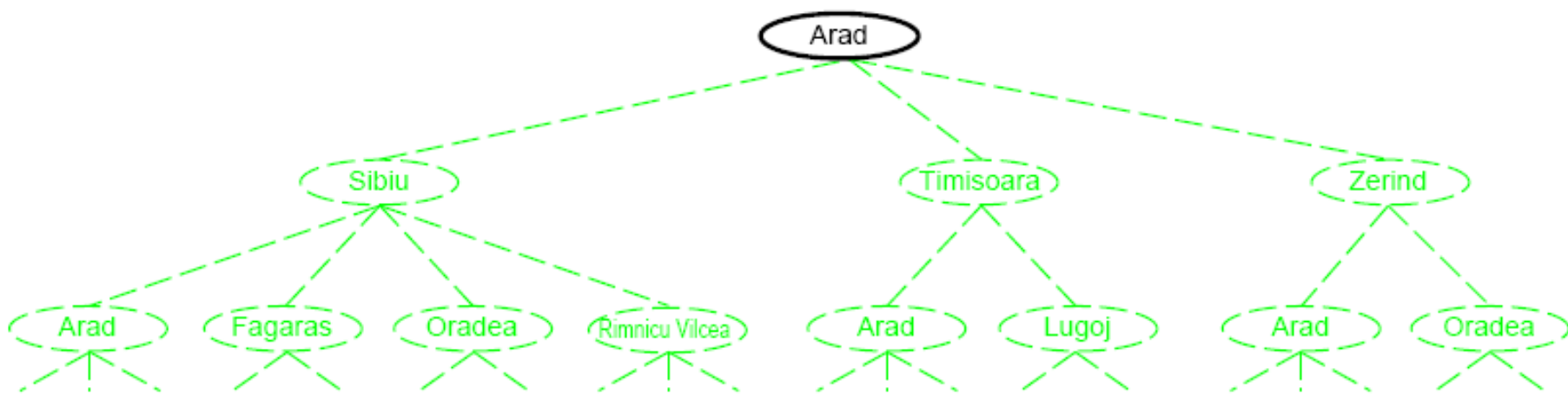

Tree Search Example

- Initial state: start with node Arad

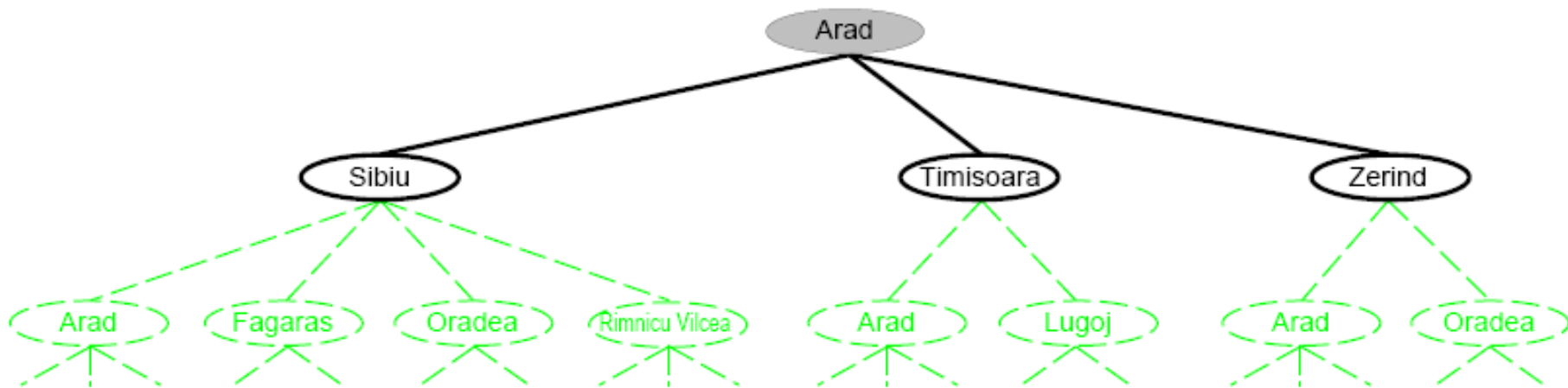

Tree Search Example

- Initial state: start with node Arad
- expand node Arad



Tree Search Example

- Initial state: start with node Arad
- expand node Arad
- expand node Sibiu

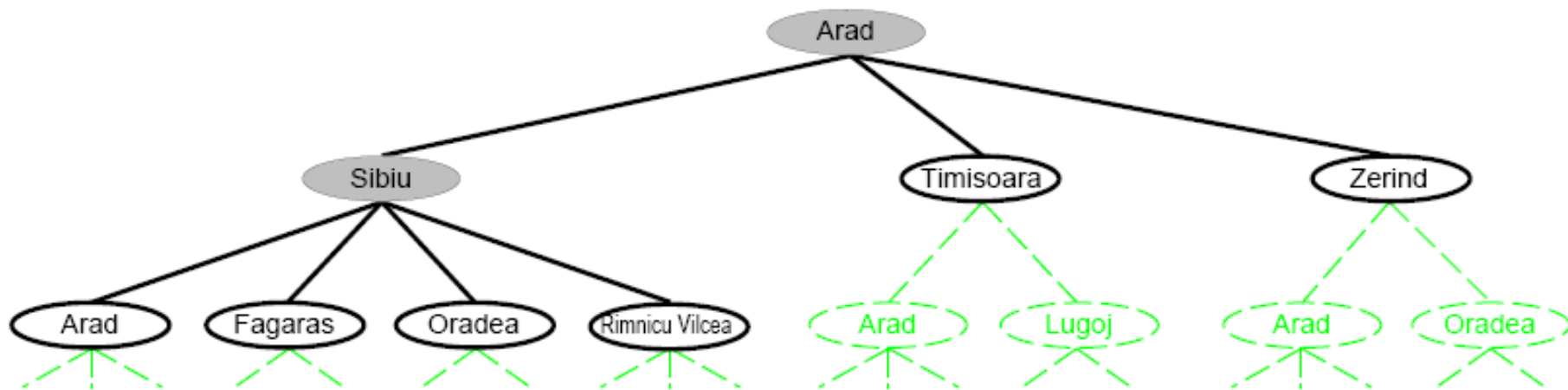

Tree Search Example

- Initial state: start with node Arad
- expand node Arad
- expand node Sibiu

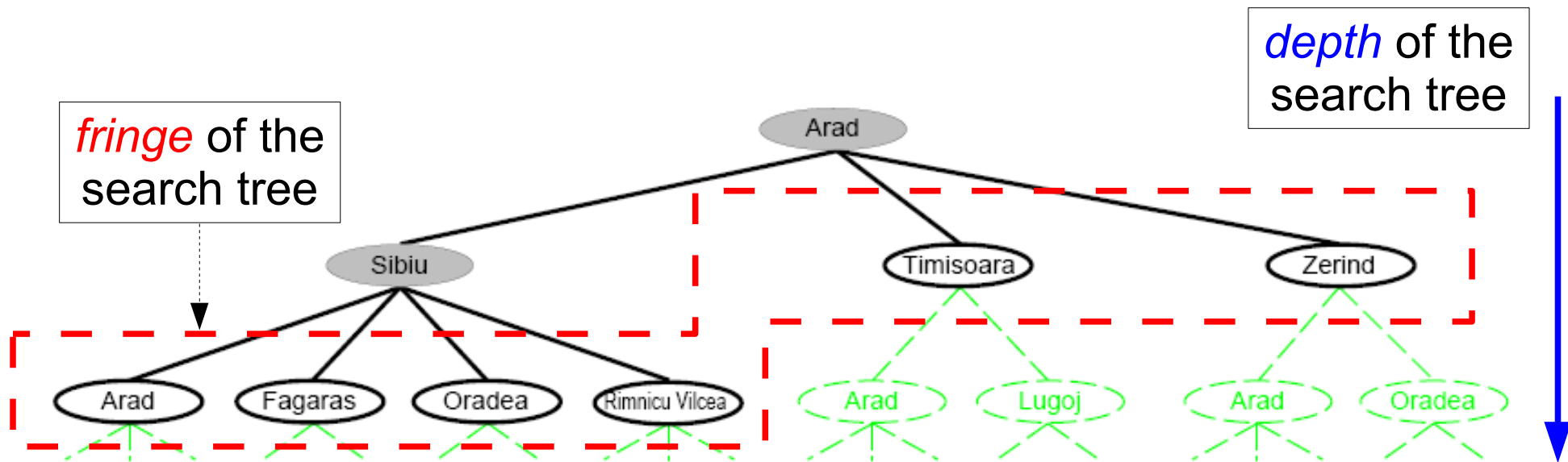

States vs. Nodes

- **State**
 - (representation of) a physical configuration
- **Node**
 - data structure constituting part of a search tree
 - includes
 - **state**
 - **parent node**
 - **action**
 - **path cost** $g(x)$
 - **depth**
- **Expand**
 - creates new nodes
 - fills in the various fields
 - uses the successor function to create the corresponding states

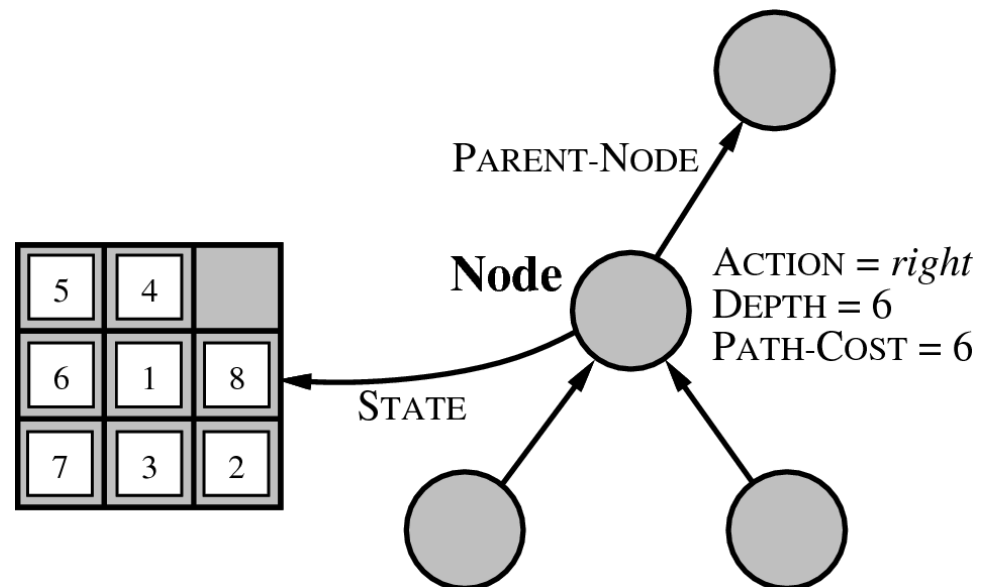

Implementation: General Tree Search

```
function TREE-SEARCH(problem, fringe) returns a solution, or failure
  fringe ← INSERT(MAKE-NODE(INITIAL-STATE[problem]), fringe)
  loop do
    if fringe is empty then return failure
    node ← REMOVE-FRONT(fringe)
    if GOAL-TEST(problem, STATE(node)) then return node
    fringe ← INSERTALL(EXPAND(node, problem), fringe)
```

```
function EXPAND(node, problem) returns a set of nodes
  successors ← the empty set
  for each action, result in SUCCESSOR-FN(problem, STATE[node]) do
    s ← a new NODE
    PARENT-NODE[s] ← node; ACTION[s] ← action; STATE[s] ← result
    PATH-COST[s] ← PATH-COST[node] + STEP-COST(node, action, s)
    DEPTH[s] ← DEPTH[node] + 1
    add s to successors
  return successors
```

Search Strategies

- A search strategy is defined by picking the **order of node expansion**
 - implementation in a queue
- Strategies are evaluated along the following dimensions:
 - **completeness**: does it always find a solution if one exists?
 - **time complexity**: number of nodes generated
 - **space complexity**: maximum number of nodes in memory
 - **optimality**: does it always find a least-cost solution?
- Time and space complexity are measured in terms of
 - b : maximum branching factor of the search tree
 - d : depth of the least-cost solution
 - m : maximum depth of the state space (may be ∞)

Search Strategies

- **Uninformed** (blind) search strategies use only the information available in the problem definition
 - Breadth-first search
 - Uniform-cost search
 - Depth-first search
 - Depth-limited search
 - Iterative deepening search
- **Informed** (heuristic) search strategies have knowledge that allows to guide the search to promising regions
 - Greedy Search
 - A* Best-First Search

Breadth-First Strategy

- Expand all neighbors of a node (breadth) before any of its successors is expanded (depth)
- Implementation:
 - expand the shallowest unexpanded node
 - fringe is a FIFO queue (first-in-first-out, new nodes go to end of queue)

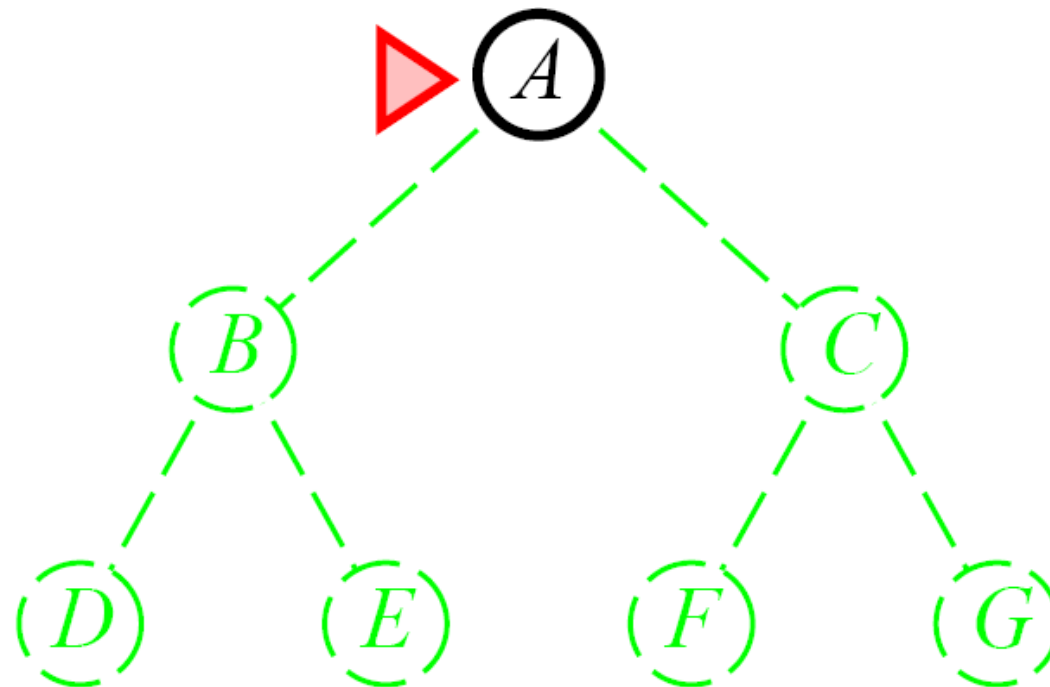

Breadth-First Strategy

- Expand all neighbors of a node (breadth) before any of its successors is expanded (depth)
- Implementation:
 - expand the shallowest unexpanded node
 - fringe is a FIFO queue (first-in-first-out, new nodes go to end of queue)

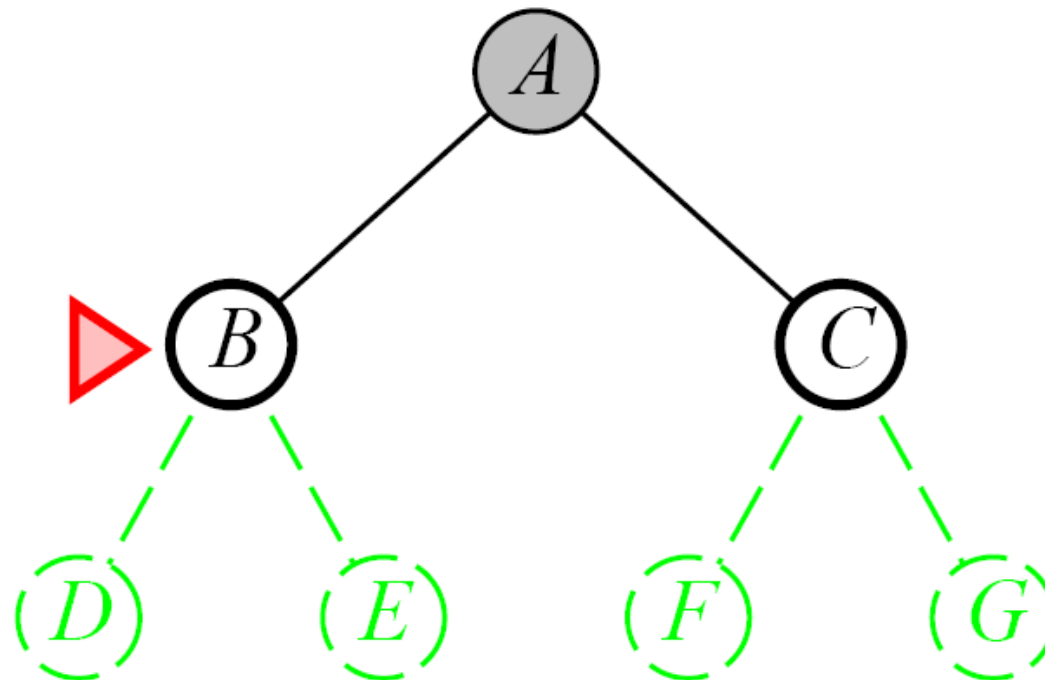

Breadth-First Strategy

- Expand all neighbors of a node (breadth) before any of its successors is expanded (depth)
- Implementation:
 - expand the shallowest unexpanded node
 - fringe is a FIFO queue (first-in-first-out, new nodes go to end of queue)

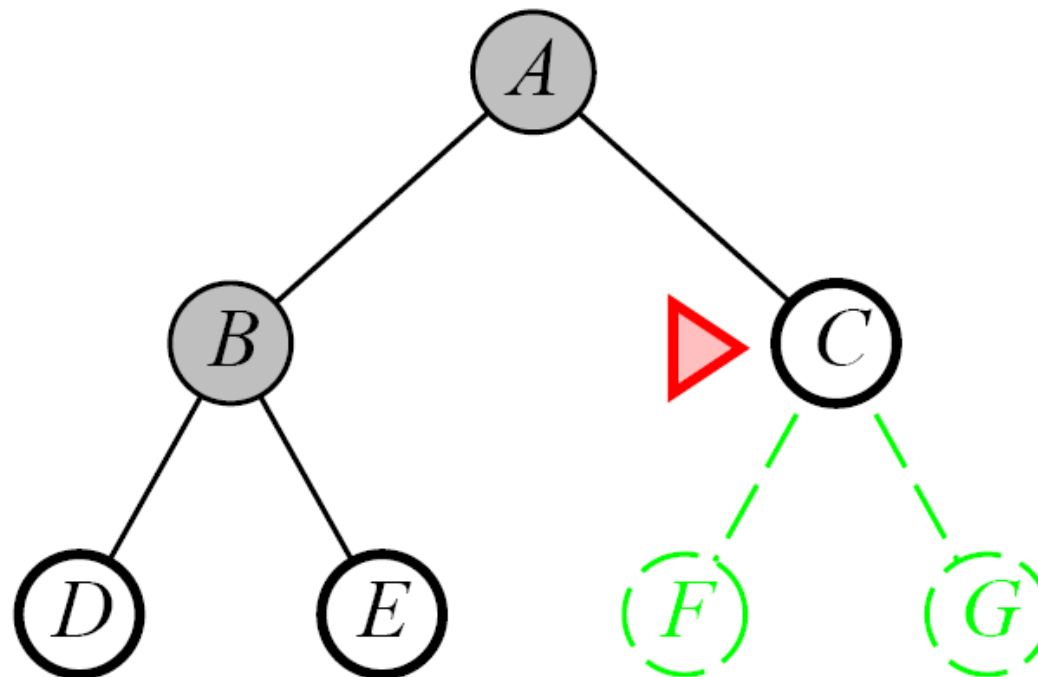

Breadth-First Strategy

- Expand all neighbors of a node (breadth) before any of its successors is expanded (depth)
- Implementation:
 - expand the shallowest unexpanded node
 - fringe is a FIFO queue (first-in-first-out, new nodes go to end of queue)

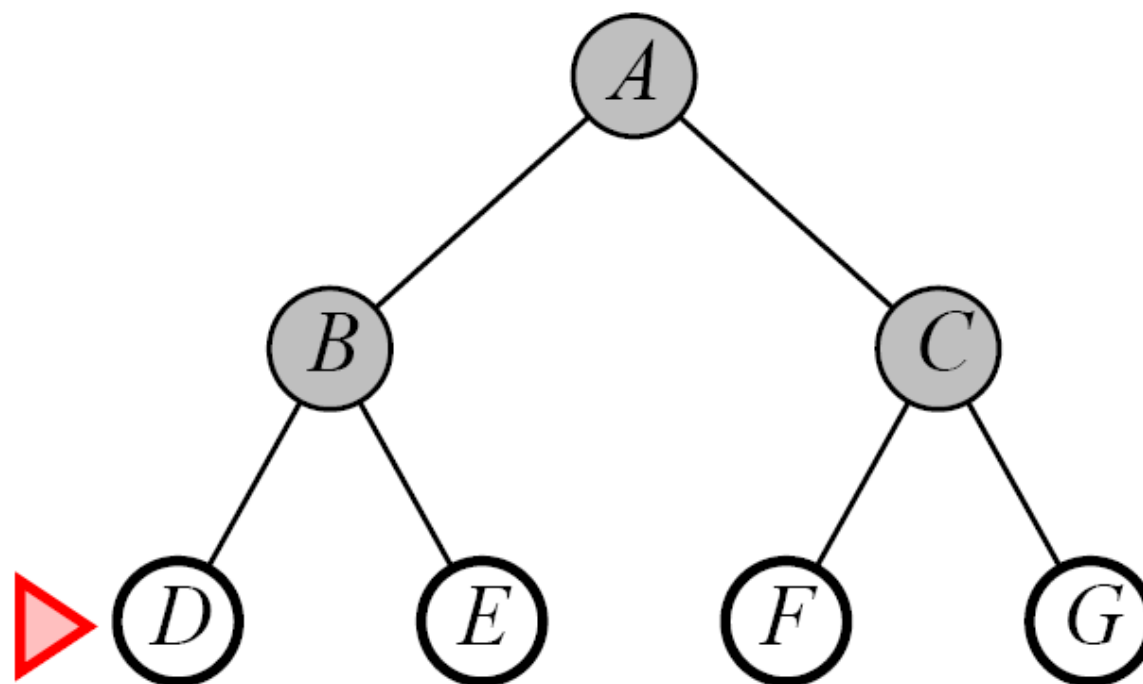

Properties of Breadth-First Search

- **Completeness**

- Yes (if b is finite)

- **Time Complexity**

- each depth has b times as many nodes as the previous
 - each node is expanded
 - except the goal node in level d
 - worst case: goal is last node in this level

$$\Rightarrow 1 + b + b^2 + b^3 + \dots + b^d + (b^{(d+1)} - b) = O(b^{d+1})$$

- **Space Complexity**

- every node must remain in memory
 - it is either a fringe node or an ancestor of a fringe node
 - in the end, the goal will be in the fringe, and its ancestors will be needed for the solution path

$$\Rightarrow O(b^{d+1}) / O(b^d)$$

- **Optimality**

- Yes, for uniform costs (e.g., if cost = 1 per step)

If goal-property is checked right after generation instead before expansion, it reduces to $O(b^d)$

Combinatorial Explosion

- Breadth-first search
 - branching factor $b = 10$, 1,000,000 nodes/sec, 1000 bytes/node

Depth	Nodes	Time	Memory
2	110	.11 msec	107 kB
4	11 110	11 msec	10.6 MB
6	10^6	1.1 sec	1 GB
8	10^8	2 minutes	103 GB
10	10^{10}	3 hours	10 TB
12	10^{12}	13 days	1 PetaBytes
14	10^{14}	3.5 years	99 PetaBytes
16	10^{16}	350 years	10 ExaBytes

- Space is the bigger problem
 - Storing 10 TB every 3 hours is a challenge...
- But Time is also quite challenging.

Uniform-Cost Search

- Breadth-first search can be generalized to cost functions
 - each node now has associated costs
 - costs accumulate over path
 - instead of expanding the shallowest path, expand the least-cost unexpanded node
 - breadth-first is special case where all costs are equal
- Implementation
 - fringe = queue ordered by path cost
- **Completeness**
 - yes, if each step has a positive cost (cost $\geq \epsilon$)
 - otherwise infinite loops are possible
- **Space and Time complexity** $b^{1+O(\lceil C^*/\epsilon \rceil)}$
 - number of nodes with costs $<$ costs of optimal solution C^*
- **Optimality**
 - Yes – nodes expanded in increasing order of path costs

Depth-First Strategy

- Expand all successors of a node (depth) before any of its neighbors is expanded (breadth)
- Implementation:
 - expand the deepest unexpanded node
 - fringe is a LIFO queue (last-in-first-out, new nodes at begin of queue)

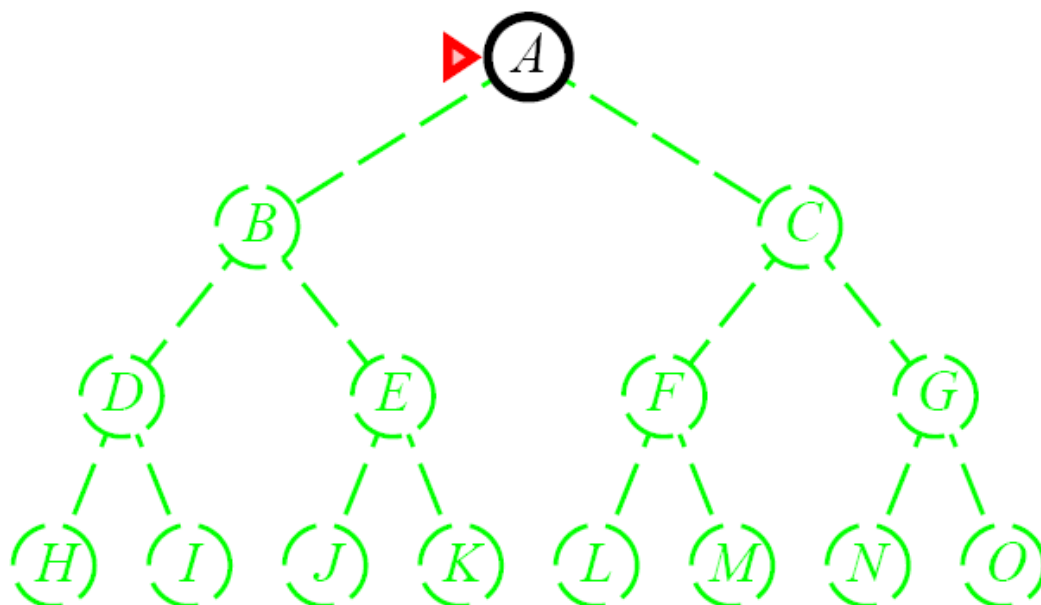

Depth-First Strategy

- Expand all successors of a node (depth) before any of its neighbors is expanded (breadth)
- Implementation:
 - expand the deepest unexpanded node
 - fringe is a LIFO queue (last-in-first-out, new nodes at begin of queue)

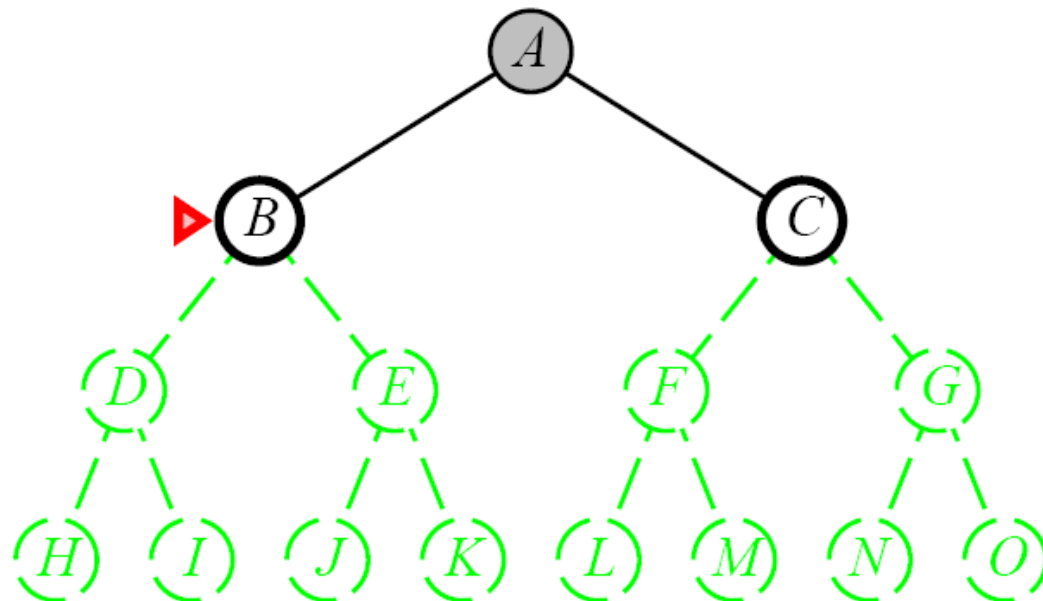

Depth-First Strategy

- Expand all successors of a node (depth) before any of its neighbors is expanded (breadth)
- Implementation:
 - expand the deepest unexpanded node
 - fringe is a LIFO queue (last-in-first-out, new nodes at begin of queue)

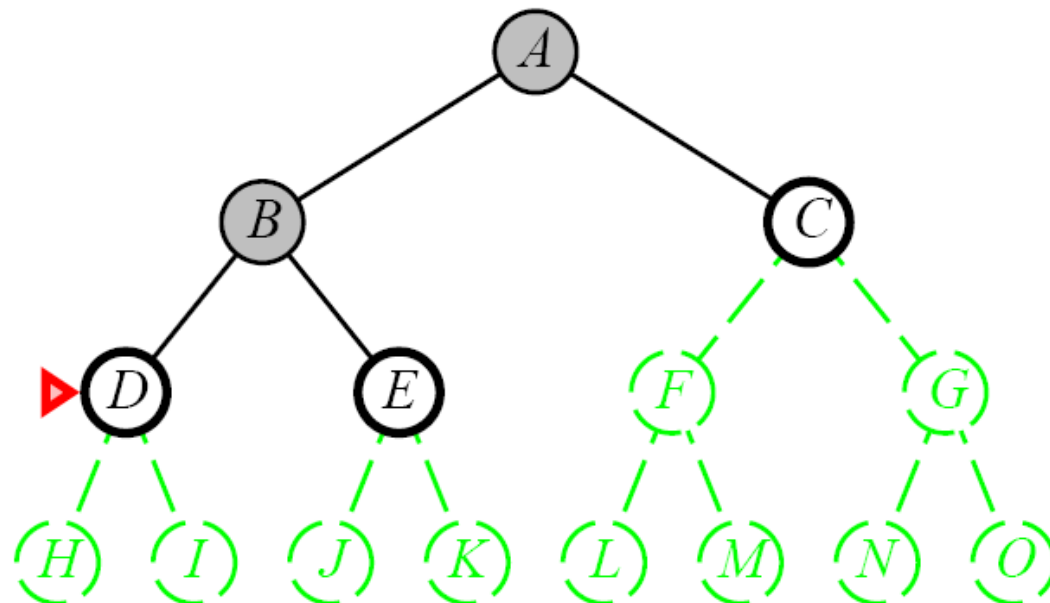

Depth-First Strategy

- Expand all successors of a node (depth) before any of its neighbors is expanded (breadth)
- Implementation:
 - expand the deepest unexpanded node
 - fringe is a LIFO queue (last-in-first-out, new nodes at begin of queue)

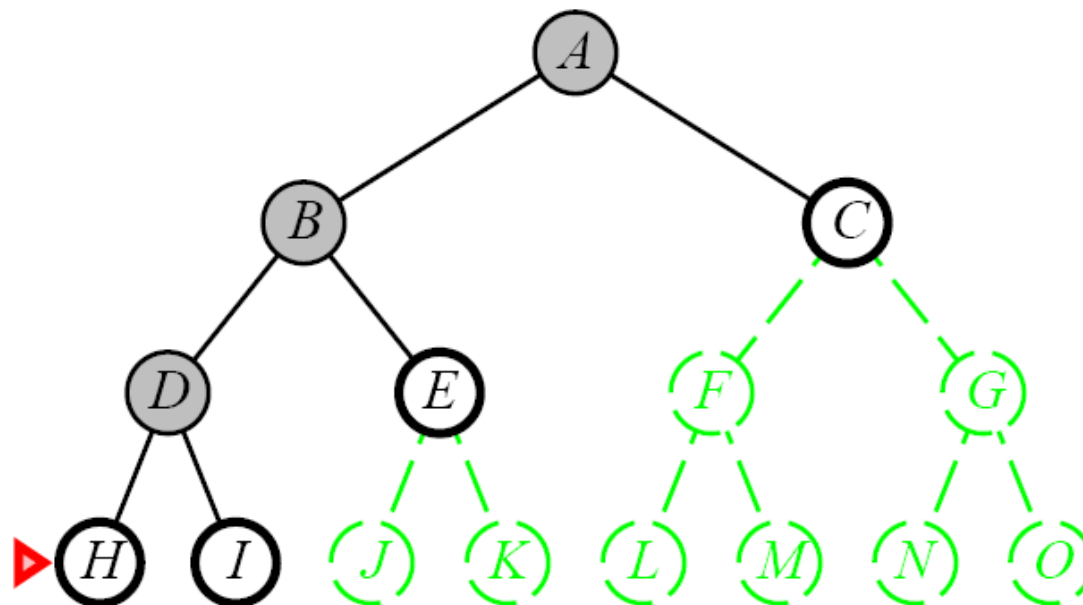

Depth-First Strategy

- Expand all successors of a node (depth) before any of its neighbors is expanded (breadth)
- Implementation:
 - expand the deepest unexpanded node
 - fringe is a LIFO queue (last-in-first-out, new nodes at begin of queue)

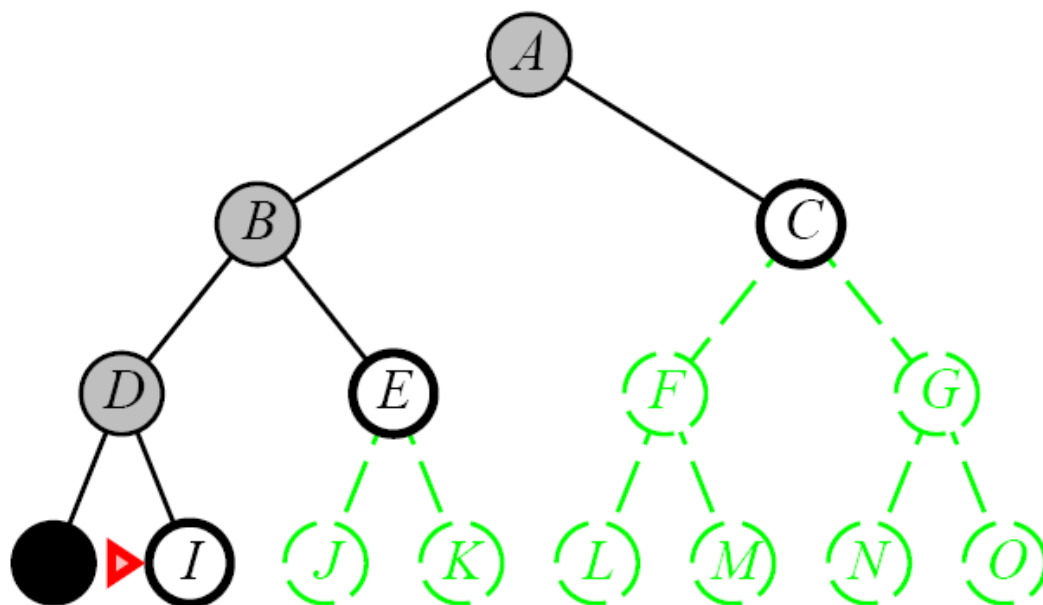

Depth-First Strategy

- Expand all successors of a node (depth) before any of its neighbors is expanded (breadth)
- Implementation:
 - expand the deepest unexpanded node
 - fringe is a LIFO queue (last-in-first-out, new nodes at begin of queue)

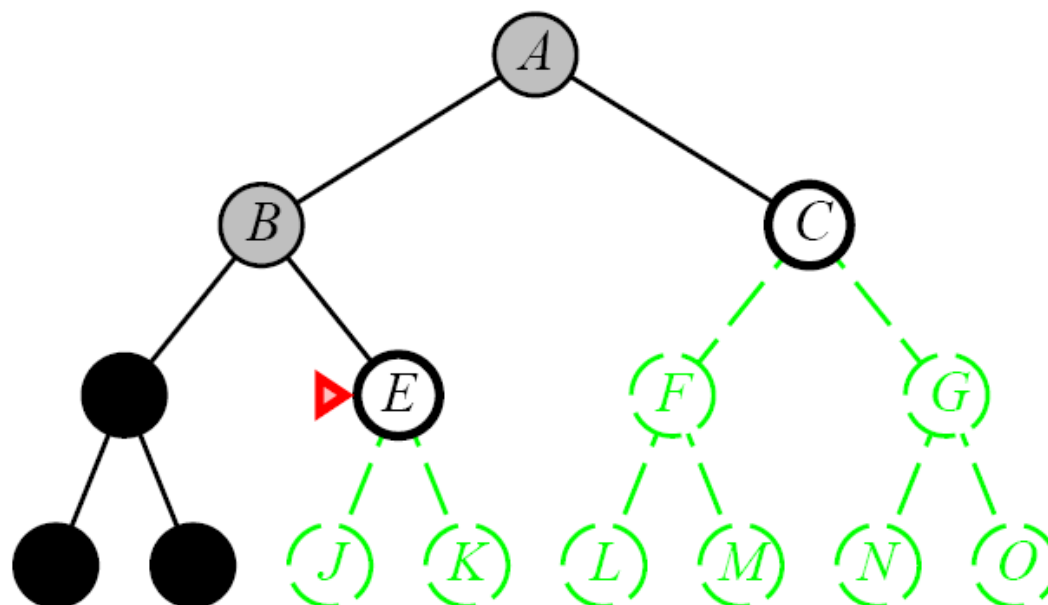

Depth-First Strategy

- Expand all successors of a node (depth) before any of its neighbors is expanded (breadth)
- Implementation:
 - expand the deepest unexpanded node
 - fringe is a LIFO queue (last-in-first-out, new nodes at begin of queue)

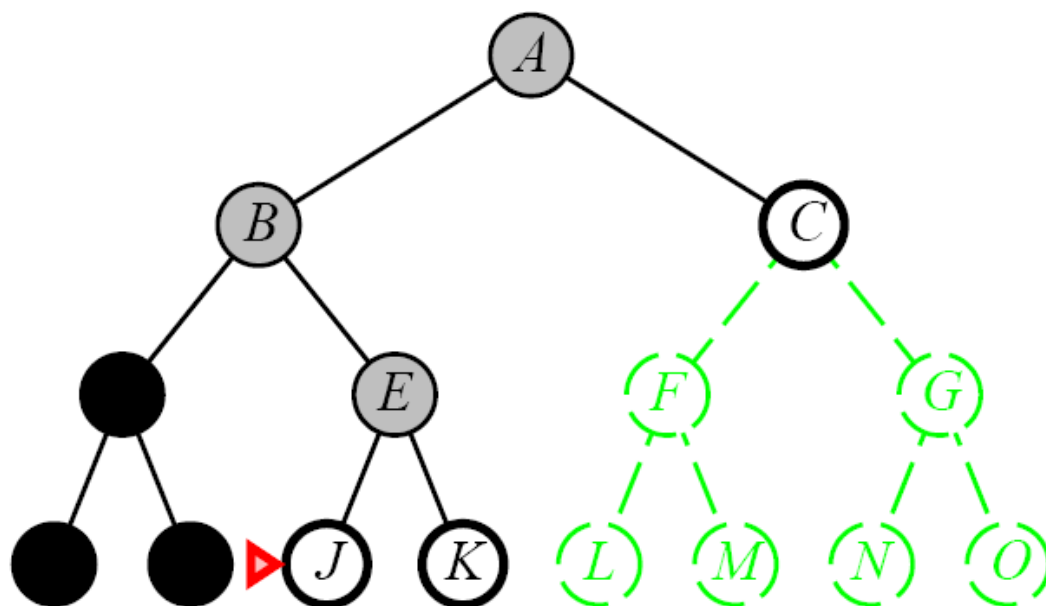

Depth-First Strategy

- Expand all successors of a node (depth) before any of its neighbors is expanded (breadth)
- Implementation:
 - expand the deepest unexpanded node
 - fringe is a LIFO queue (last-in-first-out, new nodes at begin of queue)

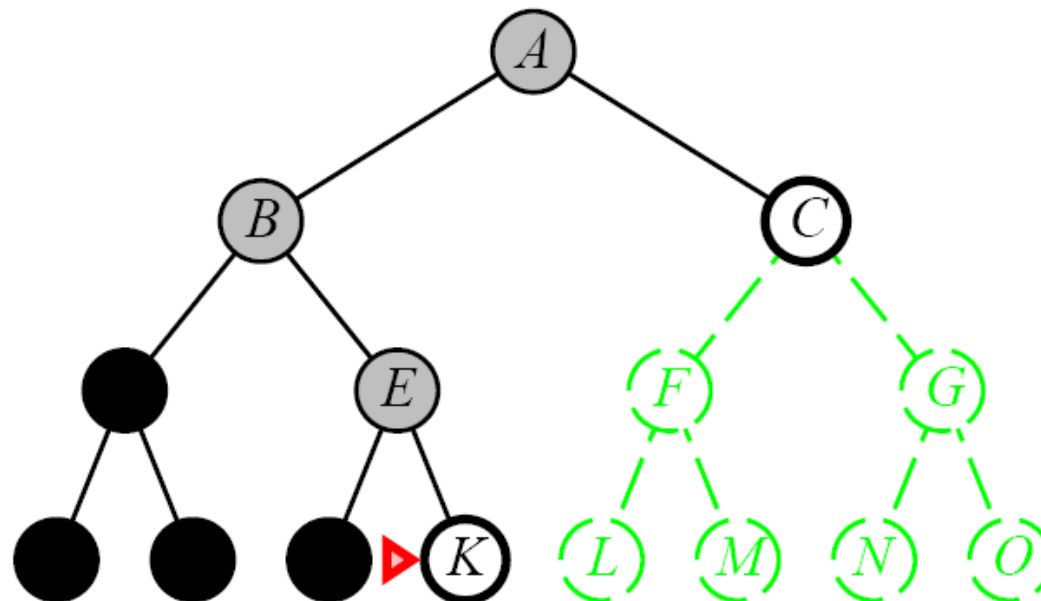

Depth-First Strategy

- Expand all successors of a node (depth) before any of its neighbors is expanded (breadth)
- Implementation:
 - expand the deepest unexpanded node
 - fringe is a LIFO queue (last-in-first-out, new nodes at begin of queue)

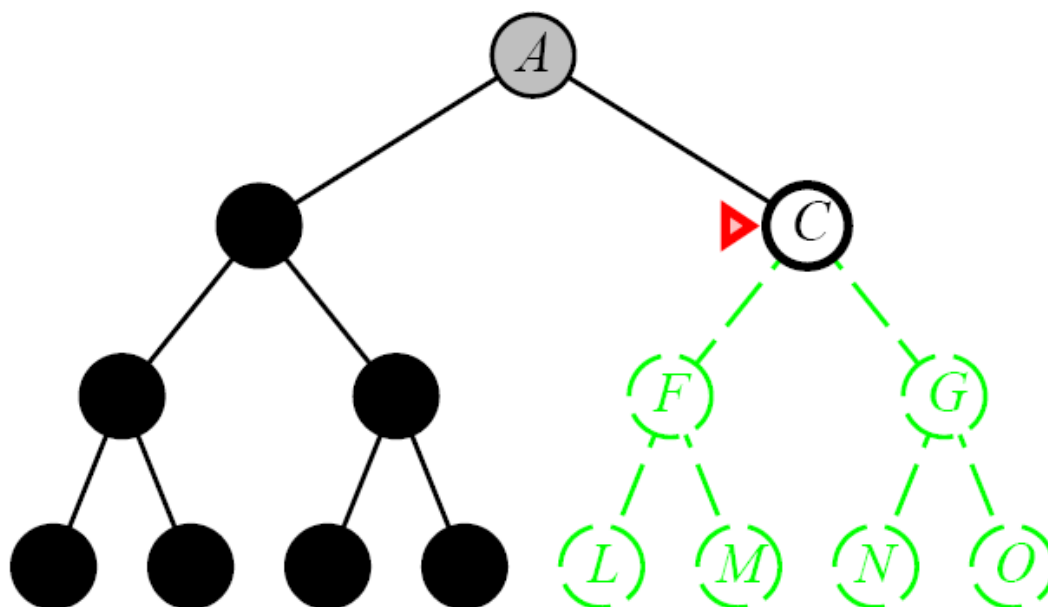

Depth-First Strategy

- Expand all successors of a node (depth) before any of its neighbors is expanded (breadth)
- Implementation:
 - expand the deepest unexpanded node
 - fringe is a LIFO queue (last-in-first-out, new nodes at begin of queue)

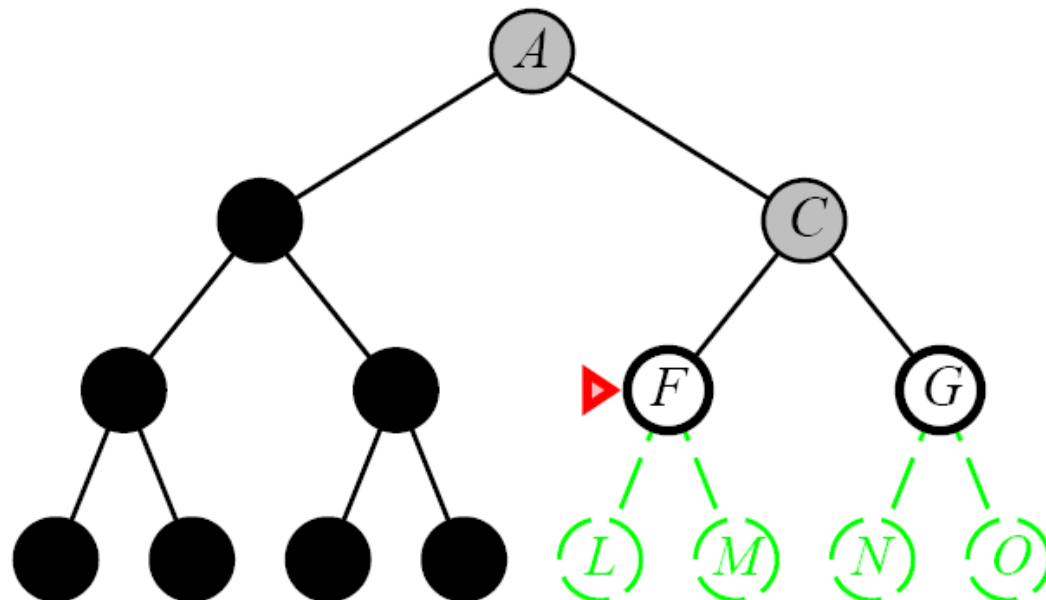

Depth-First Strategy

- Expand all successors of a node (depth) before any of its neighbors is expanded (breadth)
- Implementation:
 - expand the deepest unexpanded node
 - fringe is a LIFO queue (last-in-first-out, new nodes at begin of queue)

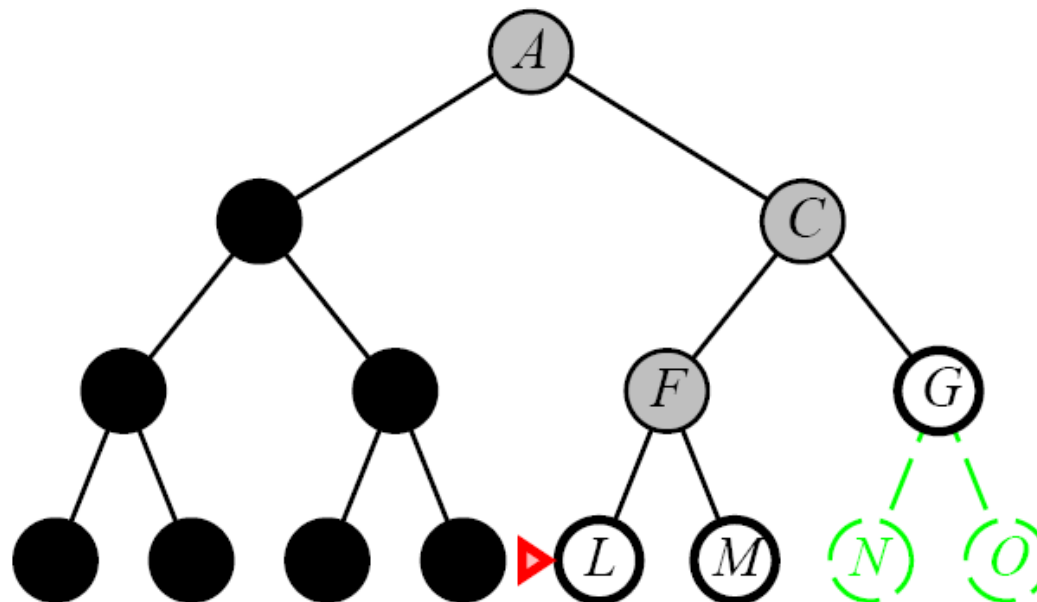

Depth-First Strategy

- Expand all successors of a node (depth) before any of its neighbors is expanded (breadth)
- Implementation:
 - expand the deepest unexpanded node
 - fringe is a LIFO queue (last-in-first-out, new nodes at begin of queue)

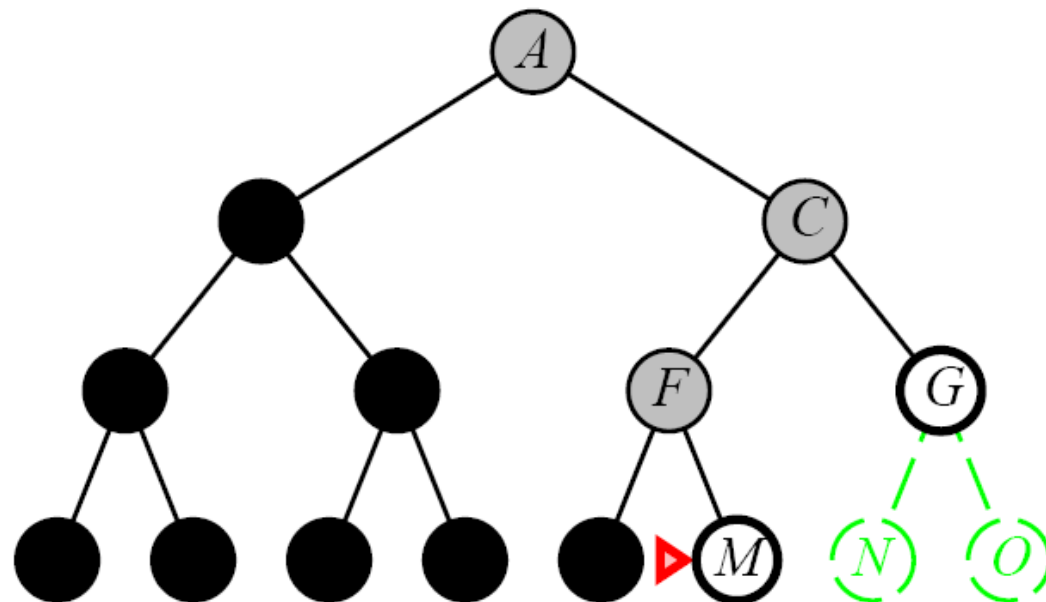

Properties of Depth-First Search

- **Completeness**
 - No, fails in infinite-depth search spaces and spaces with loops
 - complete in finite spaces if modified so that repeated states are avoided
- **Time Complexity**
 - has to explore each branch until maximum depth $m \Rightarrow O(b^m)$
 - terrible if $m > d$ (depth of goal node)
 - but may be faster than breadth-first if solutions are dense
- **Space Complexity**
 - only nodes in current path and their unexpanded siblings need to be stored
 - ⇒ only linear complexity $O(m \cdot b)$
- **Optimality**
 - No, longer (more expensive) solutions may be found before shorter (cheaper) ones

Backtracking Search

Even more space-efficient variant

- does not store all expanded nodes, but only the current path
 - ⇒ $O(m)$
 - if no further expansion is possible, go back to the predecessor
 - each node is able to generate the *next* successor
- only needs to store and modify one state
 - actions can do and undo changes on this one state

Depth-limited Search

- depth-first search is provided with a depth limit l
 - nodes with depths $d > l$ are not considered → **incomplete**
 - if $d < l$ it is **not optimal** (like depth-first search)
 - time complexity** $O(b^l)$, **space complexity** $O(bl)$

```
function DEPTH-LIMITED-SEARCH(problem, limit) returns soln/fail/cutoff
  RECURSIVE-DLS(MAKE-NODE(INITIAL-STATE[problem]), problem, limit)
```

```
function RECURSIVE-DLS(node, problem, limit) returns soln/fail/cutoff
  cutoff-occurred? ← false
  if GOAL-TEST(problem, STATE[node]) then return node
  else if DEPTH[node] = limit then return cutoff
  else for each successor in EXPAND(node, problem) do
    result ← RECURSIVE-DLS(successor, problem, limit)
    if result = cutoff then cutoff-occurred? ← true
    else if result ≠ failure then return result
  if cutoff-occurred? then return cutoff else return failure
```

Iterative Deepening Search

- Main problem with depth-limited search is setting of l
- Simple solution:
 - try all possible $l = 0, 1, 2, 3, \dots$

```
function ITERATIVE-DEEPENING-SEARCH(problem) returns a solution
  inputs: problem, a problem
  for depth  $\leftarrow$  0 to  $\infty$  do
    result  $\leftarrow$  DEPTH-LIMITED-SEARCH(problem, depth)
    if result  $\neq$  cutoff then return result
  end
```

- costs are dominated by the last iteration, thus the overhead is marginal

Iterative Deepening Search

Limit = 0



Limit = 1



Limit = 2

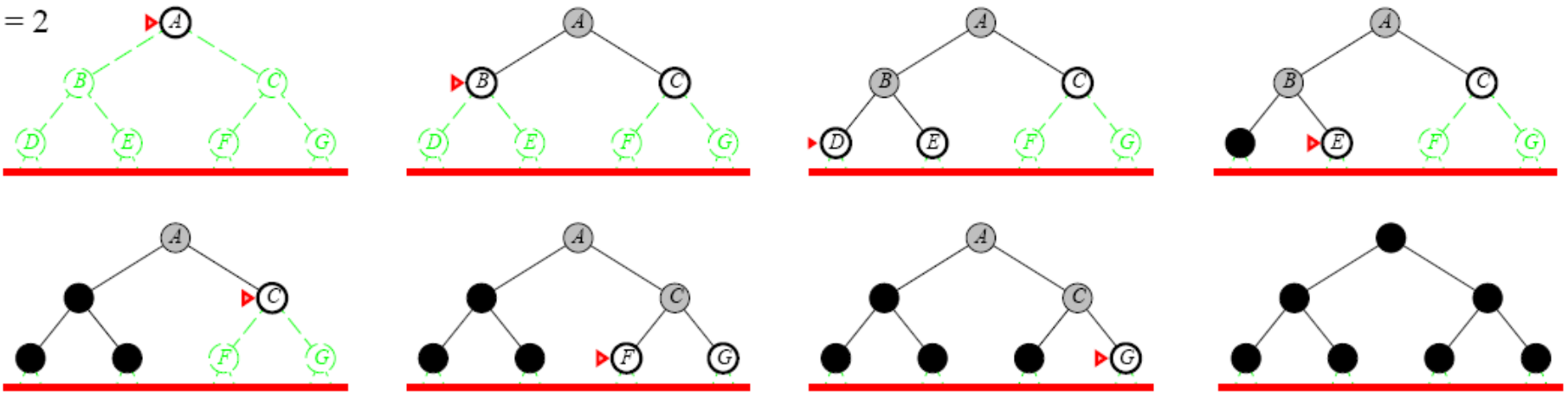

Iterative Deepening Search

Limit = 3

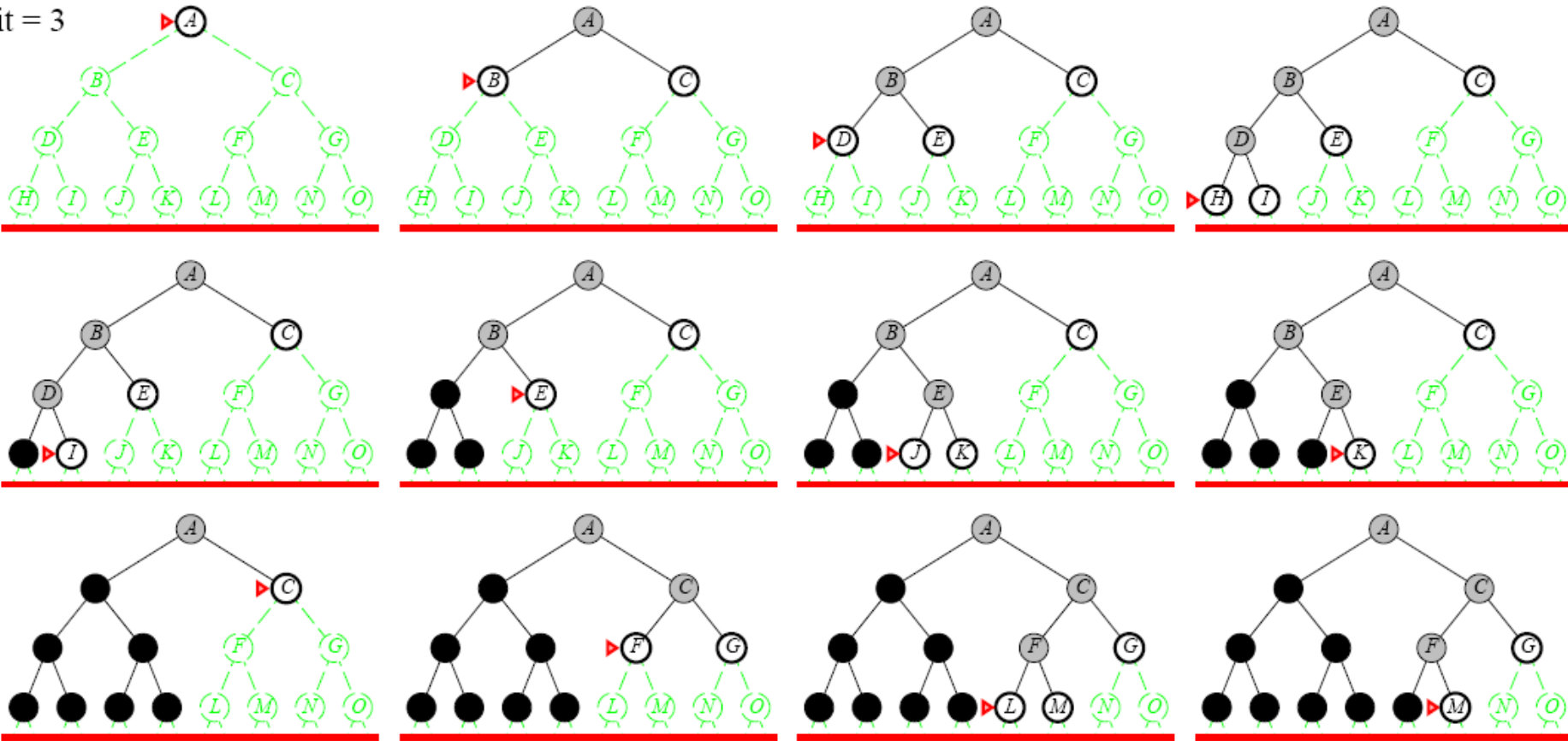

Properties of Iterative Deepening Search

- **Completeness**

- Yes (no infinite paths)

- **Time Complexity**

- first level has to be searched d times
- last level has to be searched once

$$\Rightarrow d \cdot b + (d-1)b^2 + \dots + 1 \cdot b^d = \sum_{i=1}^d (d-i+1) \cdot b^i$$

- **Space Complexity**

\Rightarrow only linear complexity $O(bd)$

- **Optimality**

- Yes, the solution is found at the minimum depth

\Rightarrow combines advantages of depth-first and breadth-first search

Comparison of Time Complexities

Worst-case (goal is in right-most node at level d)

- Depth-Limited Search

$$N_{DLS} = b + b^2 + \dots + b^d = \sum_{i=1}^d b^i$$

- Iterative Deepening

$$N_{IDS} = d \cdot b + (d-1)b^2 + \dots + 1 \cdot b^d = \sum_{i=1}^d (d-i+1) \cdot b^i$$

Example: $b = 10, d = 5$

$$N_{DLS} = 10 + 100 + 1000 + 10,000 + 100,000 = 111,110$$

$$N_{IDS} = 50 + 400 + 3000 + 20,000 + 100,000 = 123,450$$

} Overhead of
IDS only ca. 10%

Bidirectional Search

- Perform two searches simultaneously
 - forward starting with initial state
 - backward starting with goal state
- check whether generated node is in fringe of the other search

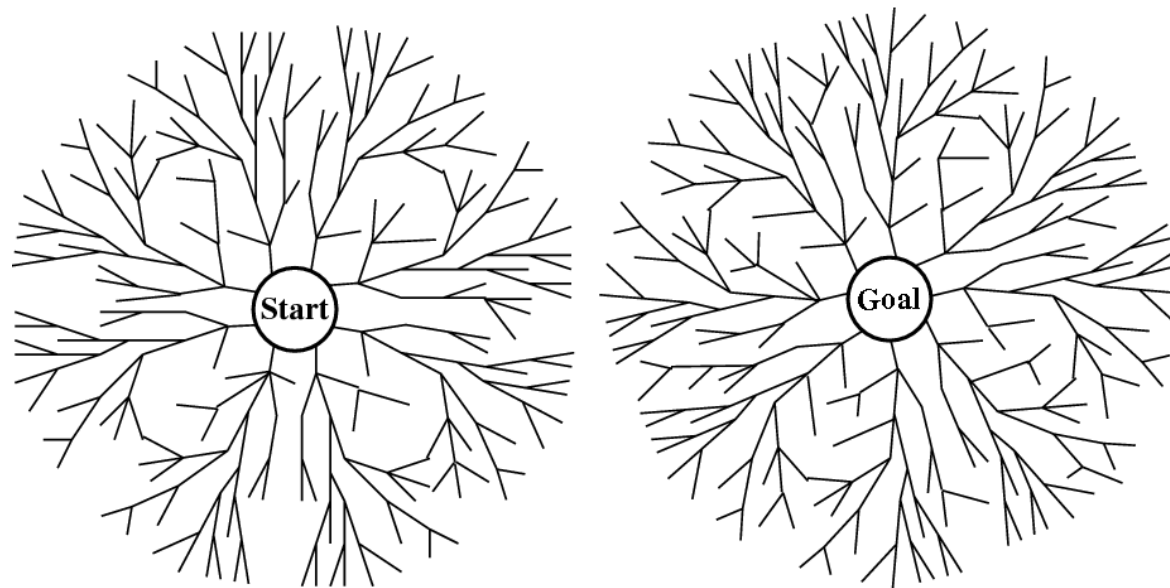

- Properties
 - reduction in complexity ($b^{d/2} + b^{d/2} \ll b^d$)
 - only possible if actions can be reversed
 - search paths may not meet for depth-first bidirectional search

Summary of Algorithms

- Problem formulation usually requires abstracting away real-world details to define a state space that can feasibly be explored
- Variety of uninformed search strategies
- Iterative deepening search uses only linear space and not much more time than other uninformed algorithms

Criterion	Breadth-First	Uniform-Cost	Depth-First	Depth-Limited	Iterative Deepening
Complete?	Yes*	Yes*	No	Yes, if $l \geq d$	Yes
Time	b^{d+1}	$b^{\lceil C^*/\epsilon \rceil}$	b^m	b^l	b^d
Space	b^{d+1}	$b^{\lceil C^*/\epsilon \rceil}$	bm	bl	bd
Optimal?	Yes*	Yes	No	No	Yes*

Assumptions about the Environment

- **static**
 - we do not pay attention to possible changes in the environment
- **observable**
 - we can at least observe our initial state
- **discrete**
 - possible actions can be enumerated
- **deterministic**
 - the expected outcome of an action is always identical to the true outcome
 - once we have a plan, we can execute it „with eyes closed“

→ easiest possible scenario

Problems with Partial Information

- **Single-State Problem**

deterministic, fully observable

- agent knows exactly which state it will be in
- solution is a sequence

- **Conformant Problem** (sensorless problem)

non-observable

- agent may have no idea where it is
- solution (if any) is a sequence

- **Contingency Problem**

nondeterministic and/or partially observable

- percepts provide new information about current state
- solution is a contingent plan (tree) or a policy
- search and execution often interleaved

- **Exploration Problem**

state-space is not known

→ Reinforcement Learning

Example: Vacuum World

- **Single-state Problem**
 - start in #5
 - goal
 - no dirt
- **Solution**
 - [*Right, Suck*]

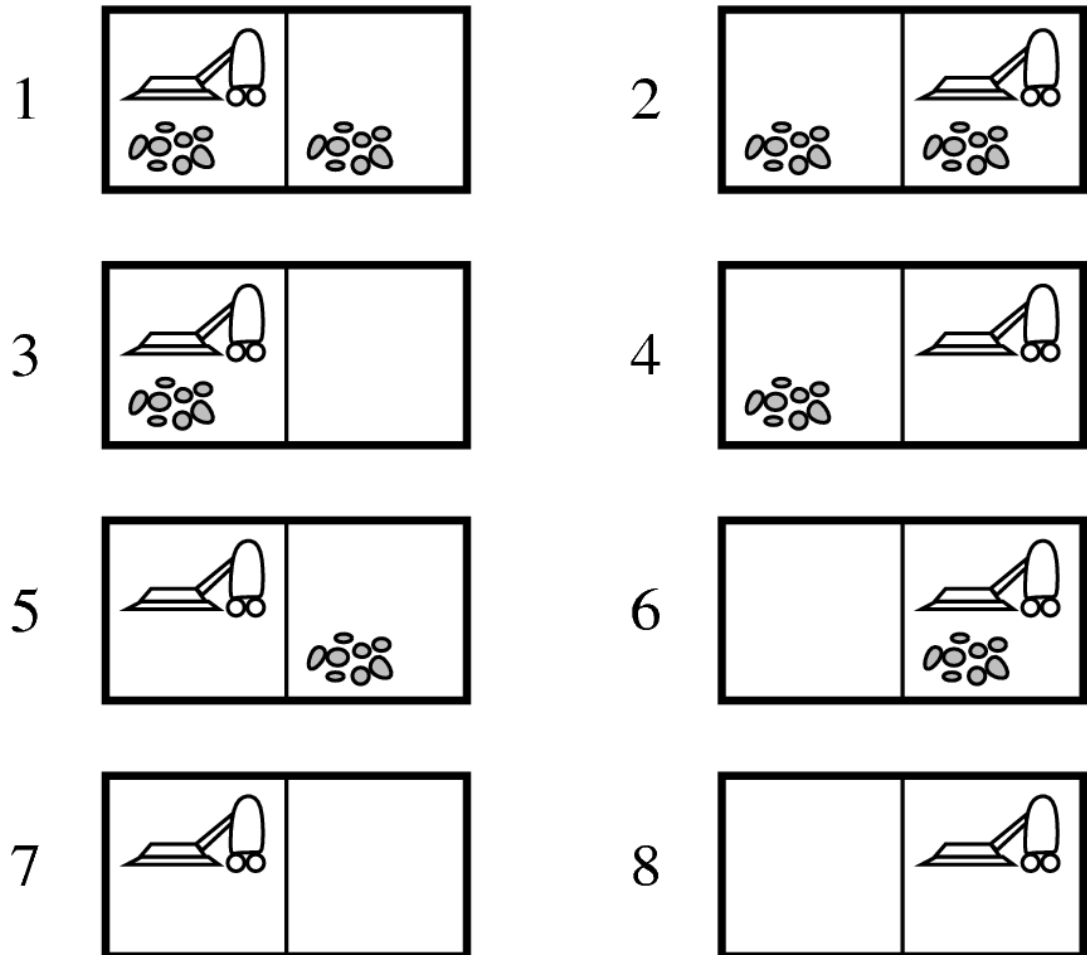

Example: Vacuum World

Conformant Problem

- start in any state (we can't sense)
 - $start \leftarrow \{1,2,3,4,5,6,7,8\}$
- actions
 - e.g., *Right* goes to $\{2,4,6,8\}$
- goal
 - no dirt

Solution

- $[Right, Suck, Left, Suck]$

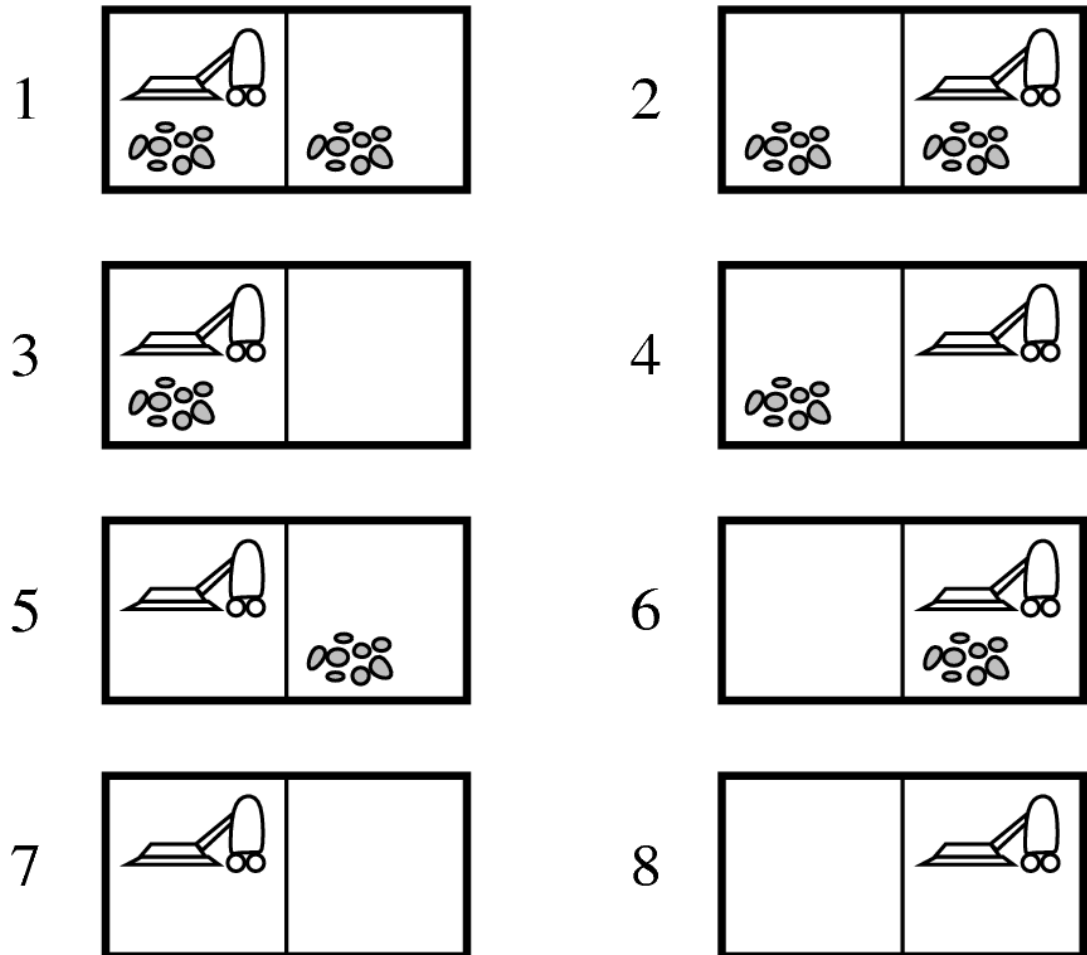

Example: Vacuum World

- **Contingency Problem**
 - start in #5
 - indeterministic actions
 - *Suck* can dirty a clean carpet
 - sensing
 - dirt at current location?
 - goal
 - no dirt
- **Solution**
 - [*Right, if dirt then Suck*]

